



Digital Pad Eye Tester

Allows you to proof test your pad eyes to ensure a successful lift



Lightweight, portable tool for testing pad eyes, lifting lugs, and eye bolts. It can be used upright, inverted, or in a horizontal plane. Models are available up to 30 ton proof test capability. Equipped with an adjustable clevis height and Digital Mounted Display.

Our Unique Digital Pad Eye Tester

There are many pad eye testers in the market however the main unique difference with LMS pad eye tester is the on board 'Digital display' (Tonnes, US Ton, Lbs, Kg) as well as the additional options to transmit the information wirelessly to a Handheld Display, a Laptop or PC and finally the Bluetooth feature for use with a Mobile Phone, Tablet or Laptop.

Display Options

- Standard - On Board Digital Display

Additional Display Options

- Wireless - Laptop or Handheld Display
- Data Logging - Laptop
- Bluetooth - Mobile & Table App

(Additional display options available upon request)

Load Monitoring Systems Ltd

Claymore Drive,
Aberdeen Energy Park,
Aberdeen, United Kingdom,
AB23 8GD.

✉ nathanm.lis@outlook.com

☎ 02 49661421



Features

- Light weight and portable
- Assist handles on two sides
- Large dial capacity readout
- Xylan coated finish
- 10ft. polyurethane hose with quick couplers
- Lightweight two-speed hand pump with locking handle
- Proof tested and calibrated
- Carrying case

Applications

Proof testing pad eyes, lifting lugs, and eye bolts. Can be used upright as pictured, inverted, or in a horizontal plane



www.loadmonitoringsystems.com

Eye Pad Tester

TECHNICAL INFORMATION

Padeye Tester Dimensions (mm)												
SWL	A	B	C	D	øE	F	G	H	I	J	øK	Weight
10te	124.5	258.5	188.5	99.5	70.5	77	78.5	471	120	52	33	11.5kg
30te	203	330	188.5	99.5	115	96	100	767	234	72	53	56kg

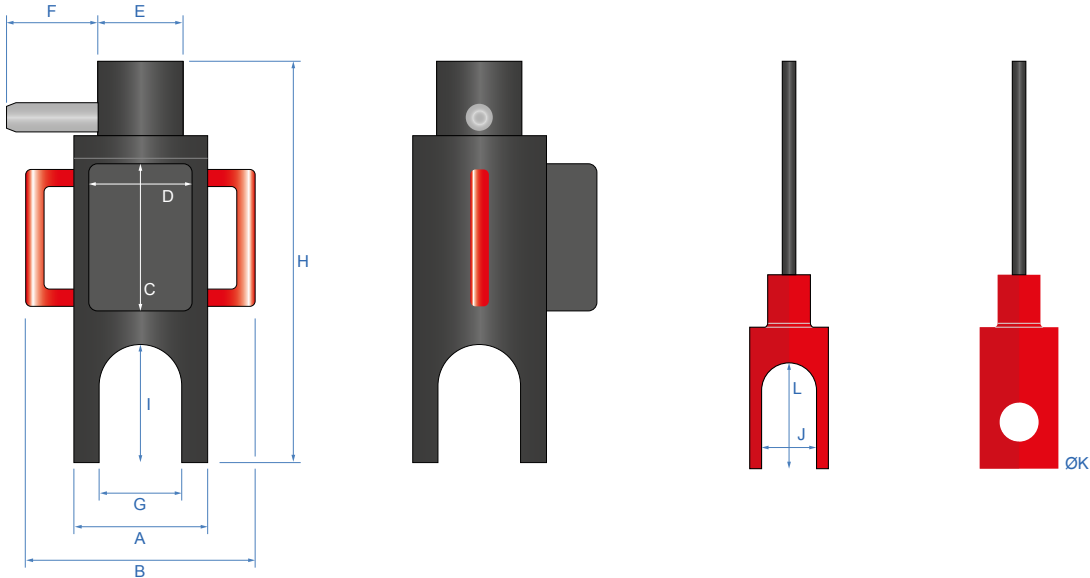

Spec		
Battery Type & Lifespan - 8 x AA 1.5V @ 80 hours +		
Safety Factor - 4:1		
IP Rating - IP65		
Stroke - Variable with adjustable threaded length		
Proof loaded - 125%		
Calibration - <1% of FSD, valid for 12 Months		
Warranty - 12 Months		
Five Pins and Collar Sets -	10te Tester	30te Tester
	3.25te	9.5te
	4.75te	12te
	6.5te	13te
	8.5te	17te
	10te	30te

Features
Digital Mounted Display
Peak Value
Zero Function
Overload Warning
Displays readings in US TN, Tonnes, kg & lb
Lightweight with Handles for Easy Transport
Bluetooth Signal
Radio Wireless Signal Transmitter with a range of up to 800m
Hydraulic High pressure hoses
Hydraulic Hand pump
Threaded rod to allow varying heights
Additional threaded rod to increase the height
Hose nozzle equipped with quick coupling that can be detached from the Padeye tester for transport
Easily assembled and disassembled for transport and replacing parts

